

By: DT 15 SEP 06  
Appvd: Pat Col 15 Sep 2006Issued: 15 Jun 2005  
Revised: 14 Sep 2006**KI-178 FUEL CONTROL REORIENTATION KIT**KIT CONTENTS:

1 each	KI-178instr	kit instructions
1 each	A336-6	push-pull tube
6 each	A341-1	spacer
1 each	A522-7	mixture control
1 each	B283-10	hose (inlet)
3 each	B330-7	palnut
1 each	B330-13	palnut
1 each	B564-2	link
2 each	D543-2	spacer
1 each	D730-8	brace
1 each	D731-9	bellcrank assembly
1 each	D732-11	bracket
1 each	D732-12	stop
1 each	D735-1	sleeve
1 each	73032	gasket
1 each	392522 or MS27769-2	plug
1 each	2522710	outlet fitting
1 each	6500-04-04-SS	elbow
1 each	6600-04-04-04-SS	tee (Alternate P/N 6600-04-04-04-FG)
3 each	MS21042L3	nut
1 each	MS21042L4	nut
1 each	MS24665-132	cotter pin
6 each	NAS1149F0332P	washer
1 each	NAS1149F0432P	washer
1 each	NAS1149F0463P	washer
1 each	NAS1149F0563P	washer
3 each	NAS6603-13	bolt
1 each	NAS6604-22	bolt

INSTRUCTIONS:

1. Verify kit contents match above list. Contact RHC if any parts are missing or damaged.
2. Remove fuel control per R44 Maintenance Manual (MM) Section 6.490 steps 1 thru 9. Retain mounting hardware.

By: DT 15 SEP 06

Issued: 15 Jun 2005

Appvd: Pat Cook 15 Sep 2006

Revised: 14 Sep 2006

3. Refer to R44 Illustrated Parts Catalog (IPC) Figure 4-19F dated FEB 2003. Remove A522-7 mixture control cable. Install new A522-7 cable supplied with kit. Re-pack firewall sealant around cable housing after installation. Trim cable housing 19.75 inches beyond firewall (do not trim cable's inner wire).
4. Refer to R44 IPC Figure 4-19B dated JAN 2005 and to Figure 1. Remove C606-2 cover. Unscrew A336-5 push-pull tube from forward rod end, leaving jam nut and palnut attached to rod end. Transfer remaining rod end from A336-5 to supplied A336-6 push-pull tube. Insert open end of A336-6 thru firewall slot and screw onto rod end until it contacts jam nut.
5. On fuel control:
  - a. Refer to R44 IPC Figure 4-31D dated JAN 2005 and to Figures 1 and 2. Remove D319-1 reducer (fuel inlet fitting), and remove screen from inlet end of fuel control. Cut safety wire, and remove 2538890 cap from opposite end of screen cavity. Inspect o-rings on reducer, filter screen, and cap; replace any that are damaged. Lubricate o-rings with clean, light oil. Install cap in location previously occupied by reducer. Install filter screen and reducer on regulator-side of fuel control (ensure open end of filter screen mates with reducer). Torque cap and reducer to 65–70 in.-lb, and safety wire cap to screw on top of fuel control casting as shown in Figure 4.
  - b. Refer to Figure 3. Remove 366082 elbow and adjacent 133176 cap. Lubricate all but first two threads of 392522 or MS27769-2 plug using ample, but not excessive, B270-6 thread sealant.

#### **CAUTION**

Excess thread sealant can contaminate fuel control and flow divider.

Install plug in previous elbow location, and torque to 45–65 in.-lb. Carefully remove 951789 O-ring from 133176 cap, lubricate with clean, light oil, and transfer to 2522710 outlet fitting. Install outlet fitting in previous cap location and torque to 40–50 in.-lb.

By: DT 15 SEP 06

Issued: 15 Jun 2005

Appvd: Pat Cook 15 Sep 2006

Revised: 14 Sep 2006

- c. Refer to R44 IPC Figure 4-19F dated FEB 2005 and to Figures 2 and 5. Cut and remove safety wire from regulator cover screws. If possible, avoid cutting wire with factory seal to center hex plug.

**CAUTION**

Clamping force on regulator assembly must be maintained;  
never remove more than 2 regulator cover screws at one time.

Remove only two 362842 regulator cover screws securing D732-9 mixture cable bracket, and remove bracket. Install D732-12 stop in D732-9 bracket location, and torque regulator cover screws to 20–30 in.-lb. Next, remove opposite two 362842 screws, install D732-11 mixture cable bracket as shown, and torque screws to 20–30 in.-lb. Safety wire screw adjacent to mixture control shaft and all regulator cover screws as shown in Figure 5.

- d. Re-clock throttle and mixture control arms as shown in Figures 4 and 5. Ensure mixture safety spring remains in place while re-clocking mixture control arm. Torque throttle arm nut to 90–130 in.-lb and install new MS245665-132 cotter pin. Torque mixture arm nut to 90–100 in.-lb.
  - e. Refer to Figure 6. Modify data plate by stamping or engraving “-C” at end of engine manufacturer part number (found on late style data plates only) such that part number reads 61M23425-C. Also modify parts list number by striking or engraving an “X” through last digit and stamping or engraving “4” such that parts list number reads 2576630-4.
6. Remove D730-7 brace (ref R44 IPC Figure 4-31D dated JAN 2005) from engine and discard. Retain attaching hardware. Install D730-8 brace in lower engine case holes as shown in Figure 2. Ensure lower hole in D730-8 brace aligns with bolt hole in D730-1 manifold. Torque MS20074-06-05 brace-to-engine-case bolts to 204 in.-lb and safety wire.
  7. Refer to Figures 1 and 2. With regulator section aft as shown, install fuel control using new 73032 gasket. Use mounting hardware retained from step 2 at lower-forward and upper-aft mount holes. Include D731-9 bellcrank assembly and hardware at upper-forward mount hole as shown in Figure 1. Include D730-8 brace and additional NAS1149F0563P washer at lower-aft hole as shown in Figure 2. Torque bolts per R44 MM Section 1.320, and torque stripe bellcrank pivot bolt.
  8. Refer to R44 IPC Figure 4-31D dated JAN 2005. Remove and discard B283-8 inlet hose and inlet tee. Install B283-10 inlet hose, 6600-04-04-04-SS inlet tee, and 6500-04-04-SS elbow as shown in Figure 2. Connect B283-9 fuel return hose to elbow. Torque fittings to 135–150 in.-lb.

By: DT 15 SEP 06

Issued: 15 Jun 2005

Appvd: Pat Corp 15 Sep 2006

Revised: 14 Sep 2006

9. Refer to R44 IPC Figure 4-31D dated JAN 2005. Loosen upper end of B283-7 fuel control outlet hose at flow divider. Lubricate hose upper support clamp on engine sheet metal with liquid soap. Remove hose lower support clamp on engine sheet metal and hose support clamps at oil line. Re-orient elbow at fuel-control-end of hose approximately 180° to align with fuel control outlet fitting.

**CAUTION**

Flow divider end of B283-7 hose must be loosened prior to rotation of fuel control end to avoid twisting/restricting hose.

Connect hose to fuel control outlet, and tighten hose at flow divider. Torque hose fittings to 135–150 in.-lb. Install lower support clamp and oil line support clamps as shown in Figure 2.

10. Refer to Figure 1. Install B564-2 link from bellcrank assembly to throttle arm as shown. Torque fasteners per R44 MM Section 1.320 and torque stripe.
11. Refer to Figure 1. Connect aft end of A336-6 push-pull tube to D731-9 bellcrank assembly as shown. Adjust A336-6 push-pull tube length as required to obtain full throttle travel (collective must be raised to obtain full throttle) and correlation rigging per R44 MM Section 10.150. Verify adequate clearance between A336-6 push-pull tube, B564-2 link, and surrounding aircraft structure. Ensure both ends of A336-6 are torqued per R44 MM Section 1.320.
12. Secure mixture cable housing to D732-11 bracket with housing flush to 0.25 inch extended beyond clamps as shown in Figure 2. Torque cable housing clamp screws per R44 MM Section 1.320. Connect mixture control and adjust as required to obtain full travel and 0.03 to 0.10 inch clearance under mixture control knob when full rich. Mixture control inner wire should protrude 0.10-0.30 inch beyond A462-4 fitting at fuel control mixture arm; trim wire as required but do not bend end. Torque fitting at mixture arm to 25–30 in.-lb and verify freedom of rotation between mixture arm and control wire. If wire cannot rotate relative to mixture arm then A130 spacer on fitting may be missing or damaged; replace as required.
13. Check and adjust idle mixture and speed per R44 MM Section 6.495 steps 19 through 24. Install thermal-insulating D735-1 sleeve on inlet tee using safety wire as shown in Figure 2.
14. Recheck throttle correlation rigging per R44 MM section 10.150. Ensure both ends of A336-6 push-pull tube are torqued per R44 MM section 1.320 and torque stripe. Install C606-2 cover inside control tunnel.
15. Close and secure all panels.

2901 Airport Drive, Torrance, California 90505

Phone (310) 539-0508 Fax (310) 539-5198

By: DT 15 Sep 06

Issued: 15 Jun 2005

Appvd: Pat Cook 15 Sep 2006

Revised: 14 Sep 2006

16. Make appropriate maintenance record entries.

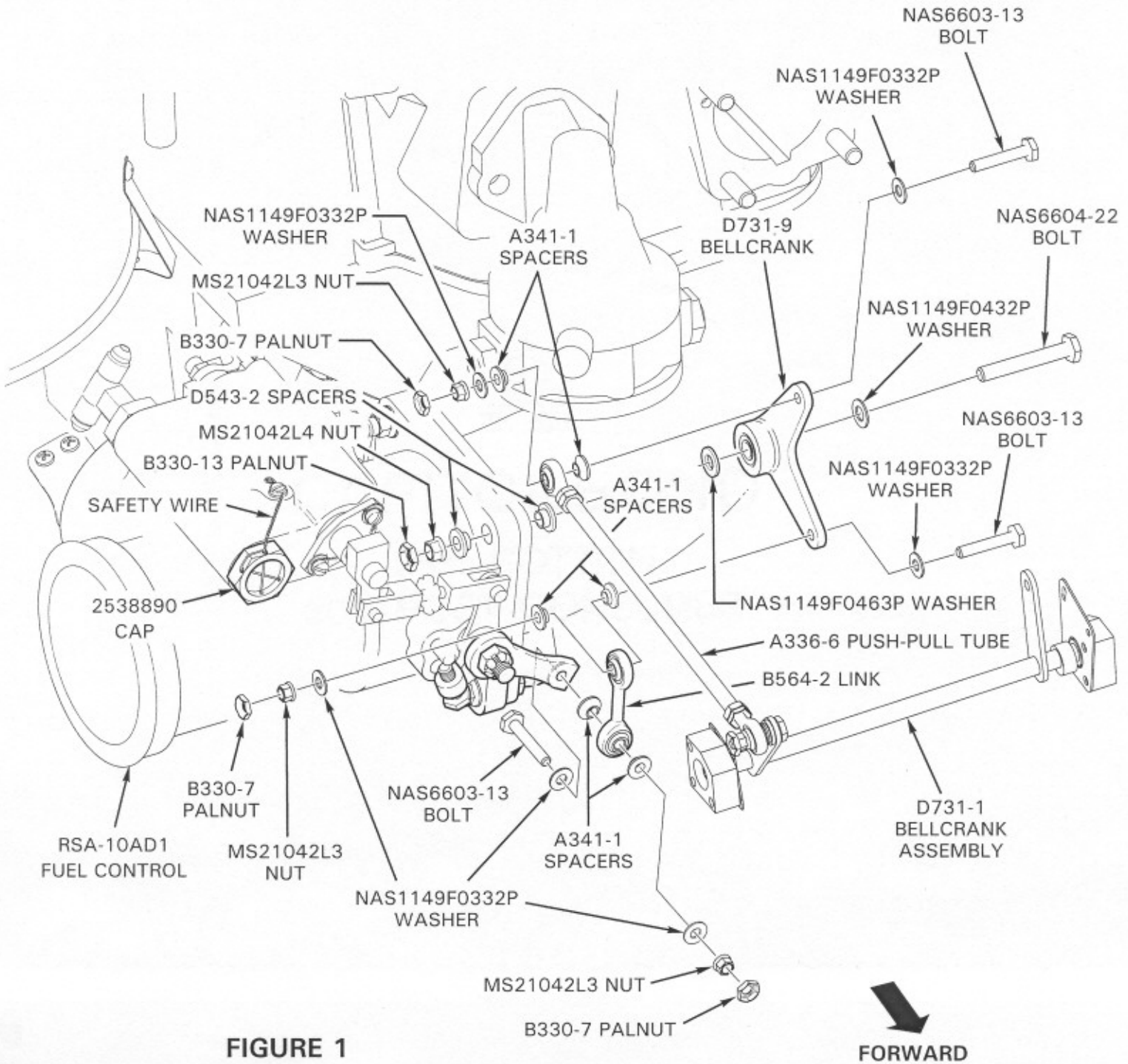

By: DT 15 SEP 06  
Appvd: Pat Cook 15 Sep 2006

Issued: 15 Jun 2005  
Revised: 14 Sep 2006

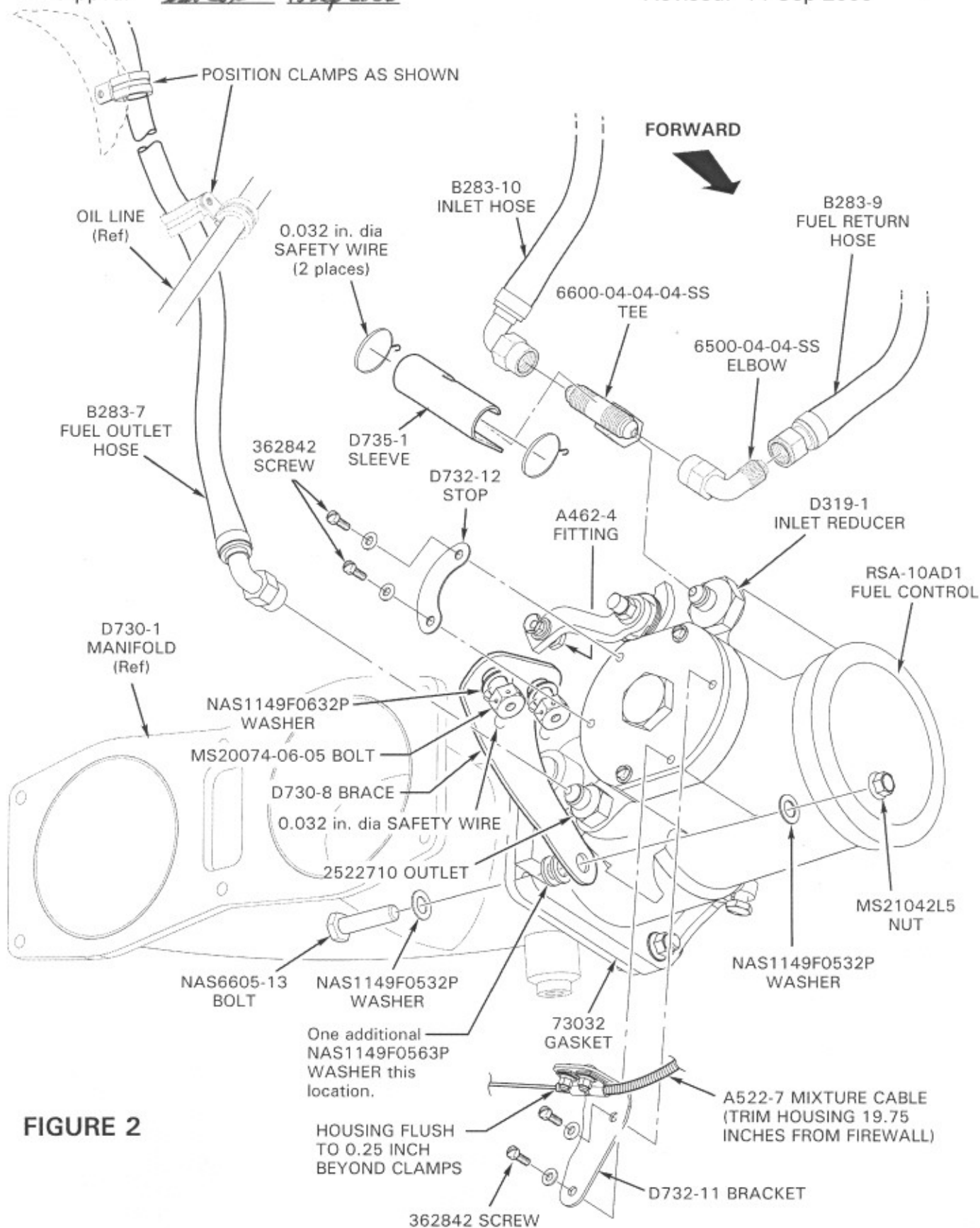

**FIGURE 2**

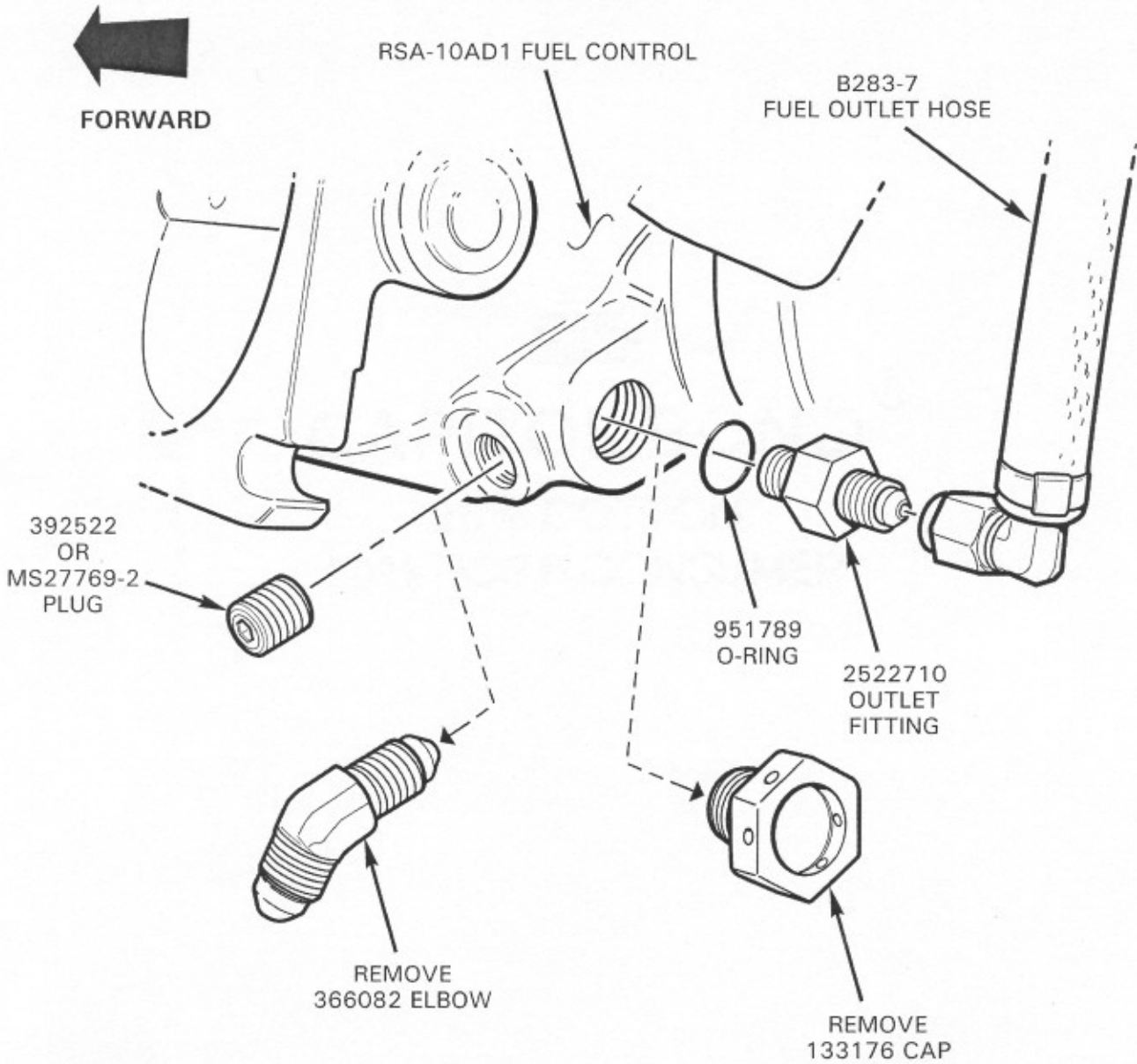

**FIGURE 3**

By: DT 15 SEP 06

Issued: 15 Jun 2005

Appvd: Pat Coy 15 Sep 2006

Revised: 14 Sep 2006

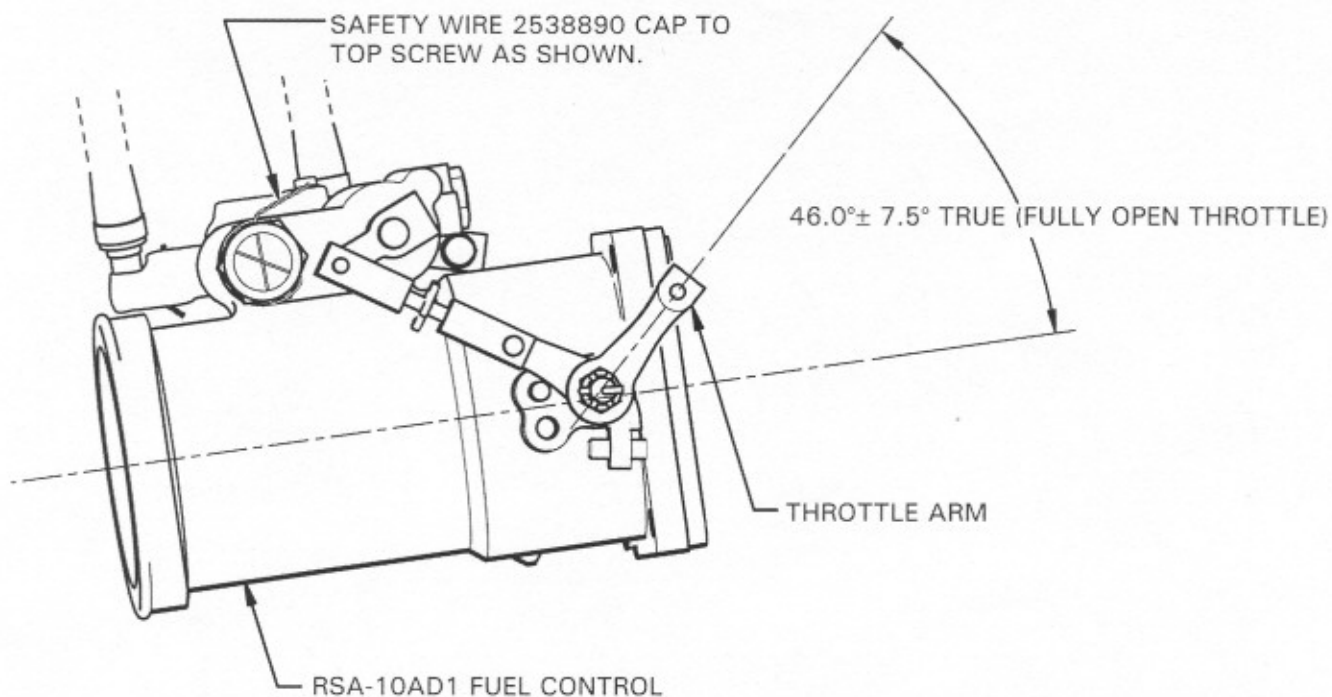

**FIGURE 4**

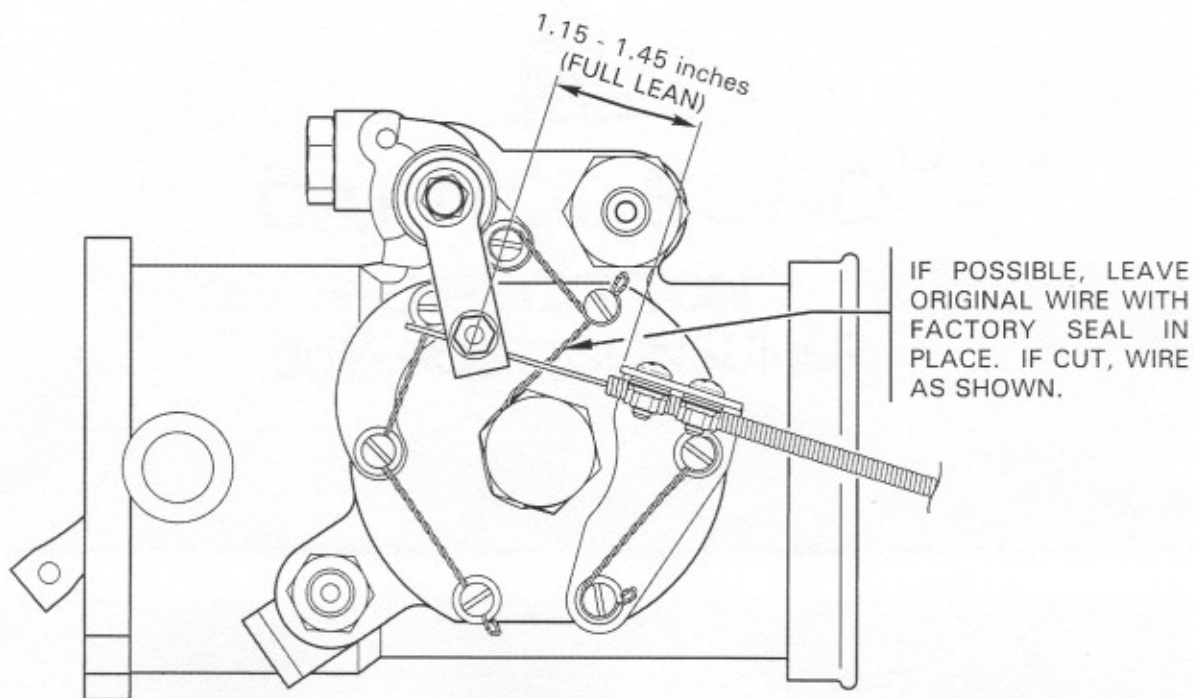

**FIGURE 5**

2901 Airport Drive, Torrance, California 90505

Phone (310) 539-0508 Fax (310) 539-5198

By: DT 15 SEP 06

Issued: 15 Jun 2005

Appvd: Pvt Capt 15 Sep 2006

Revised: 14 Sep 2006

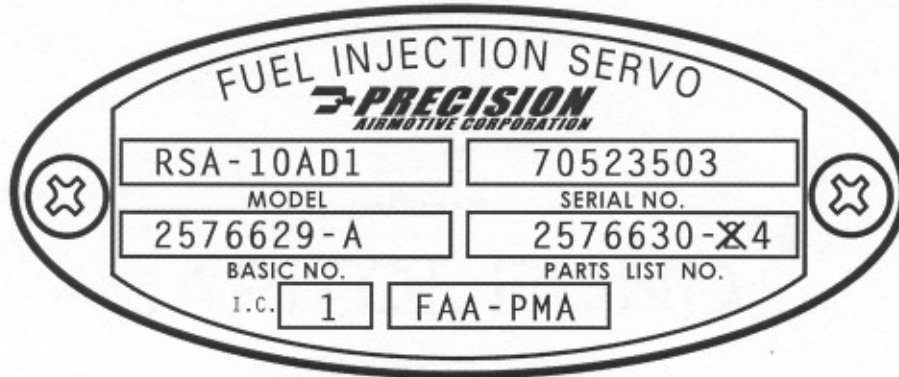

**EARLY STYLE**

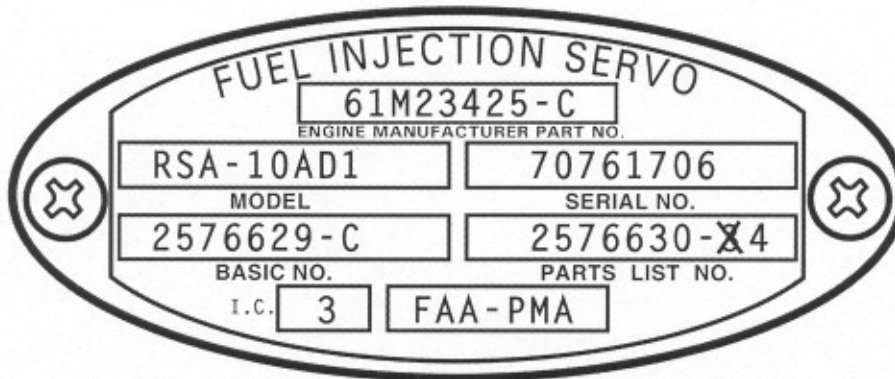

**LATE STYLE**

**FIGURE 6 FUEL CONTROL DATA PLATE MODIFICATION**